

Ejector Return Couplings – General Information

Quick Action Ejector Return Couplings for Presses with Hydraulic Ejection

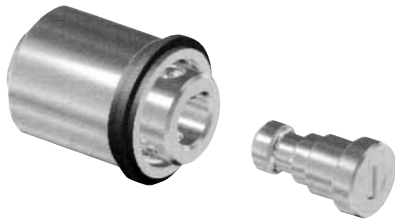

Economical

- Shortens mold changeover times
- Only one unit required per injection molding machine

Universal

- Can be put into existing molds to save time and money
- Hydraulic return by means of fixed coupling
- Pulsating ejection possible

Quick return coupling (incl. connecting plug)

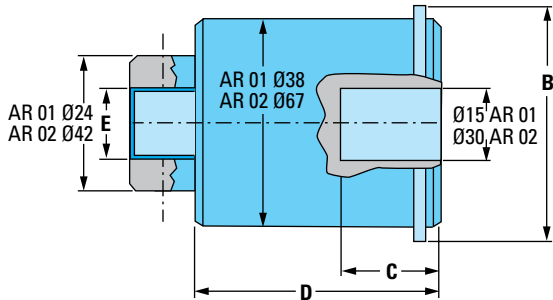

Connecting plug

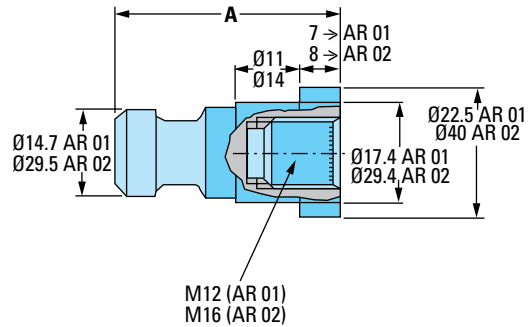

REF	TYPE
AR01 RESP. 02	QUICK RETURN COUPLING (INJECTION PRESS)
AR01 RESP. 02 P	CONNECTING PLUG (MOLD)

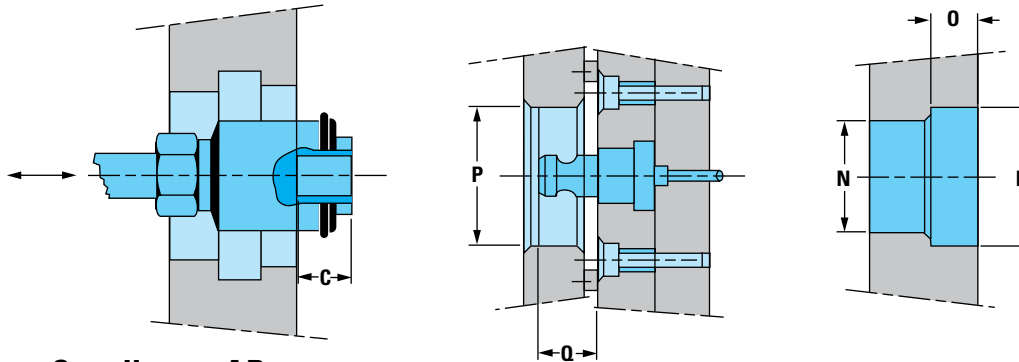

Ejector Return Couplings – AR

REF	A	B	C ±0.02	D	E	M	N	O ^{+0.05} / _{+0.02}	P MIN.	Q MIN.	kN
AR01	38	43	18	43.5	M16	23	18	7	48	C +1	40
AR02	43	73	24	70.5	M20	42	32		80	C +1	140

Installation

1. Move the ejector plate to the molding position (mold closed).
2. Move also the ejector cylinder rod to the fully retracted position. It is important to check by hand, that the rod is fully pushed back to the fully retracted position before measuring.
3. Measure the distance between the coupling and the ejector cylinder rod.
4. Extend the ejector cylinder rod with an extra knock-out rod of the measured length + 30mm for AR-01 and 50mm for AR-02.
5. Move the mold ejector plates to the forward position (mold open).
6. Lock both the extra knock-out rod and at the other end the quick coupling.
7. Move the mold ejector plates back to the mold closed position and make the coupling between ejector plate and ejector cylinder rod. Make sure that the ejector plate and ejector cylinder rod are both in the mold closed position as soon as the coupling is made. If not, adjust.

Do not use with quick-change mold systems.

